

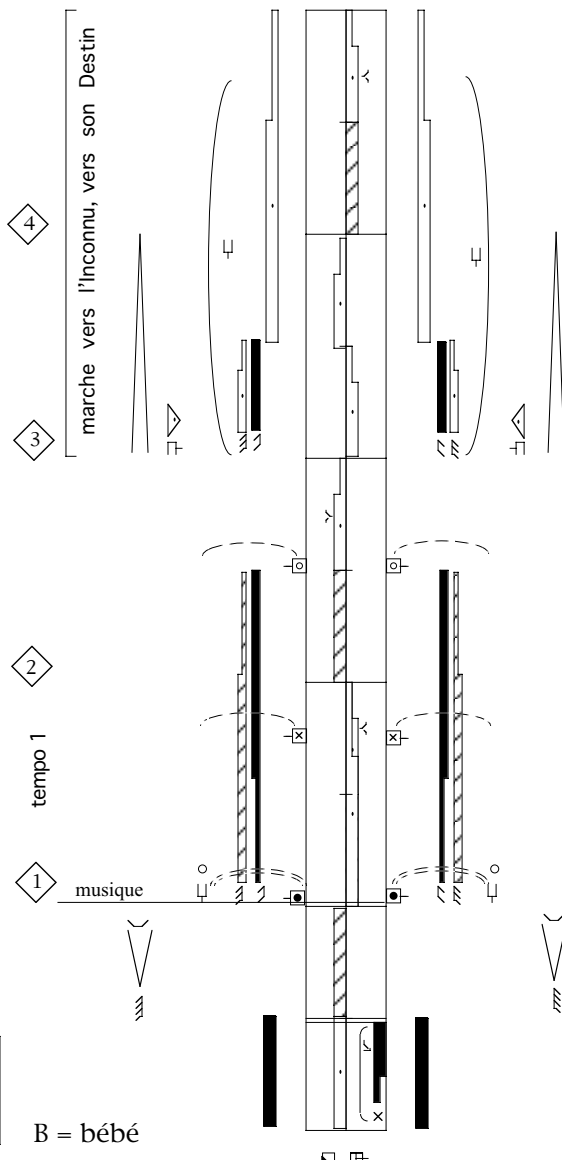

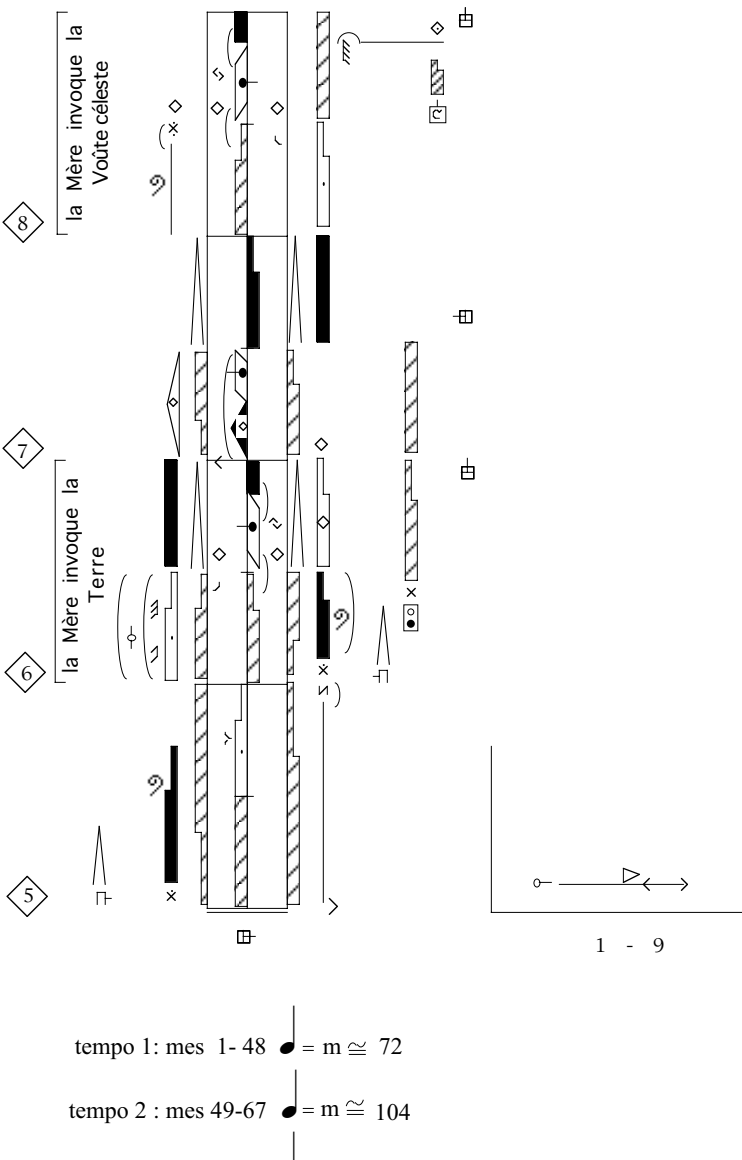

**BERCEUSE op. 38 n°1 Grieg**  
**Chorégraphie Malkovsky 1922**  
**Notation Karin Hermes-Sunke et Suzanne Bodak 1997**

2/4  B = bébé

tempo 1 : mes 1-48  = m ≈ 72

tempo 2 : mes 49-67  = m ≈ 104

tempo 1 : mes 71-86  = m ≈ 72

1 - 9

# BERCEUSE

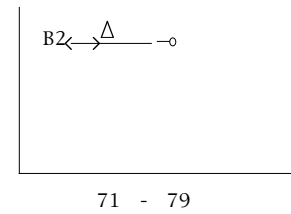
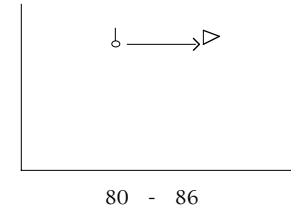
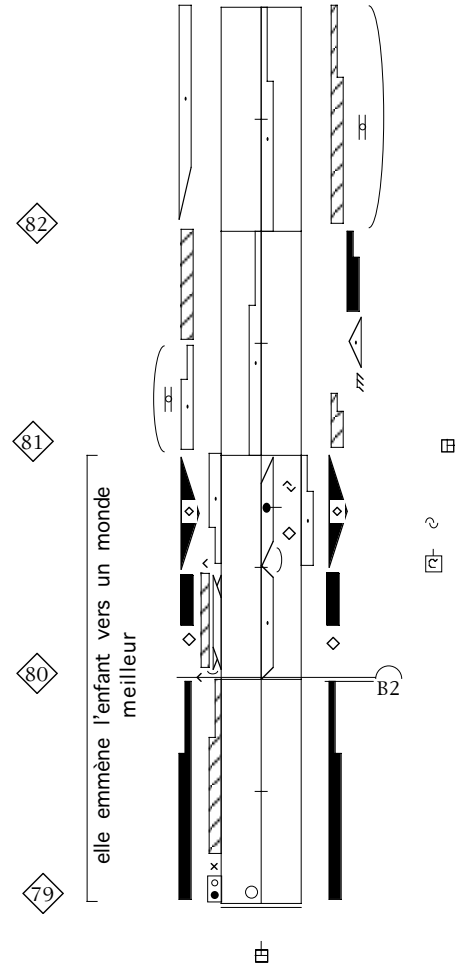
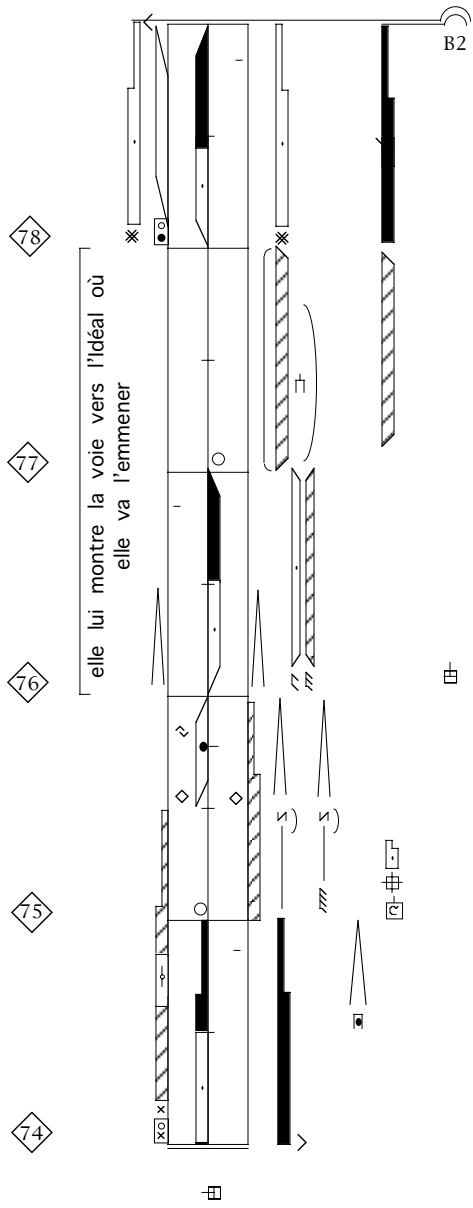

# BERCEUSE

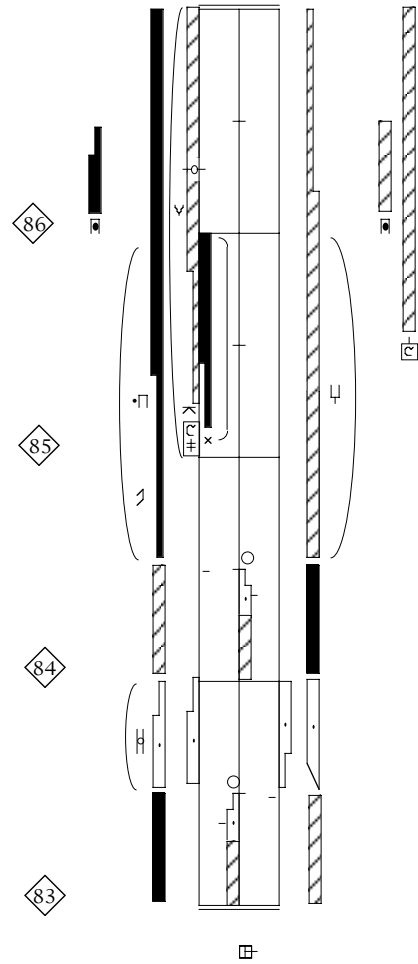

© pour la notation  
K. Hermes-Sunke & S. Bodak

# BERCEUSE

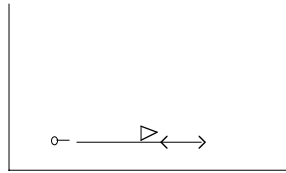

1 - 9

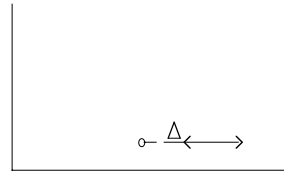

10 - 16

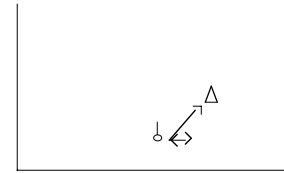

17 - 20

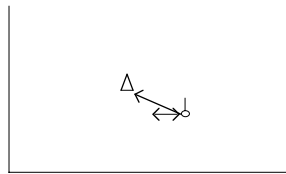

21 - 24

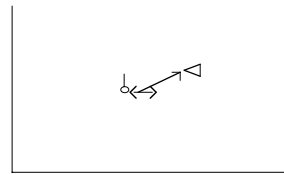

25 - 28

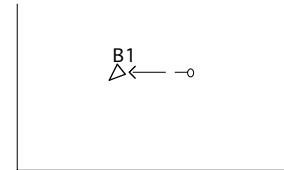

29 - 32

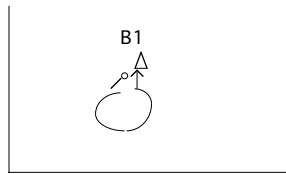

33 - 36

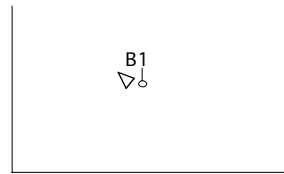

37 - 40

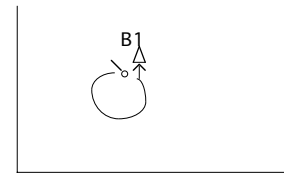

41 - 44

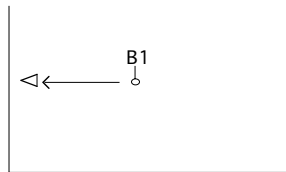

45 - 53

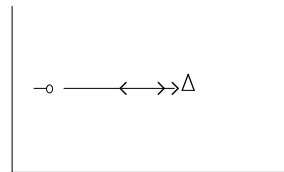

54 - 62

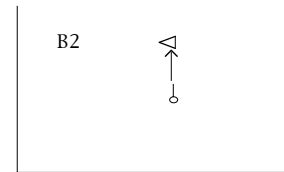

63 - 70

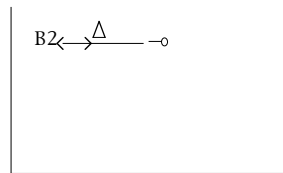

71 - 79

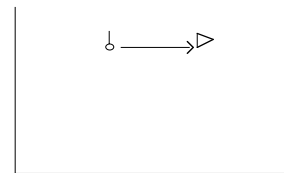

80 - 86